



Service bulletin

C
223

THE BRITISH MOTOR CORPORATION (AUSTRALIA) PTY. LIMITED

FOR THE ATTENTION OF SERVICE AND PARTS MANAGERS.

SEAT MODIFICATION

It is possible that tall owners may find the seating position more comfortable if the angle of the seat back is altered.

This may be carried out by one of the methods described below:-

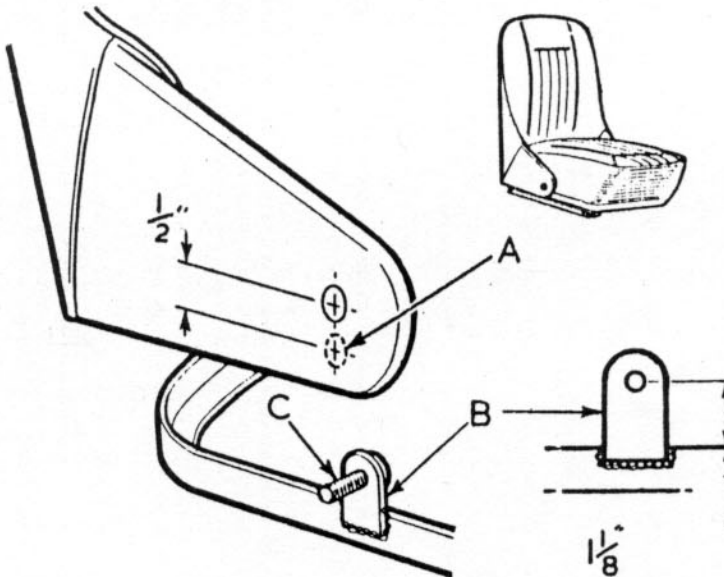

1. Remove seat back and drill an additional hole $21/64$ " dia., each side, as shown at 'A'.

Refit seat back using new holes.

2. (a) Dismantle seat and remove frame from floor.
(b) Remove bracket 'B' from frame with a cold chisel.
(c) Make a new bracket from 10 SWG strip, $\frac{1}{2}$ " longer than existing bracket.
(d) Transfer welded bolt 'C' to new bracket.
(e) Weld new bracket to seat frame so that centre-line of bolt is $1\frac{1}{8}$ " above frame.
(f) Fit frame to car and reassemble seat back.

CARS

HEALEY

SPRITE

AN5

&

MK. II

A/470

5.2.63

Page 1 of 1

N. Prescott

N. Prescott
Service Manager.